



## NOTICE DE MONTAGE KIT Complet Courier

*MODÈLE Transit Courier*  
*Année : 2014 - À ce jour*



**ASSA ABLOY**

Une marque du Groupe ASSA

# Composition du Kit 3 points

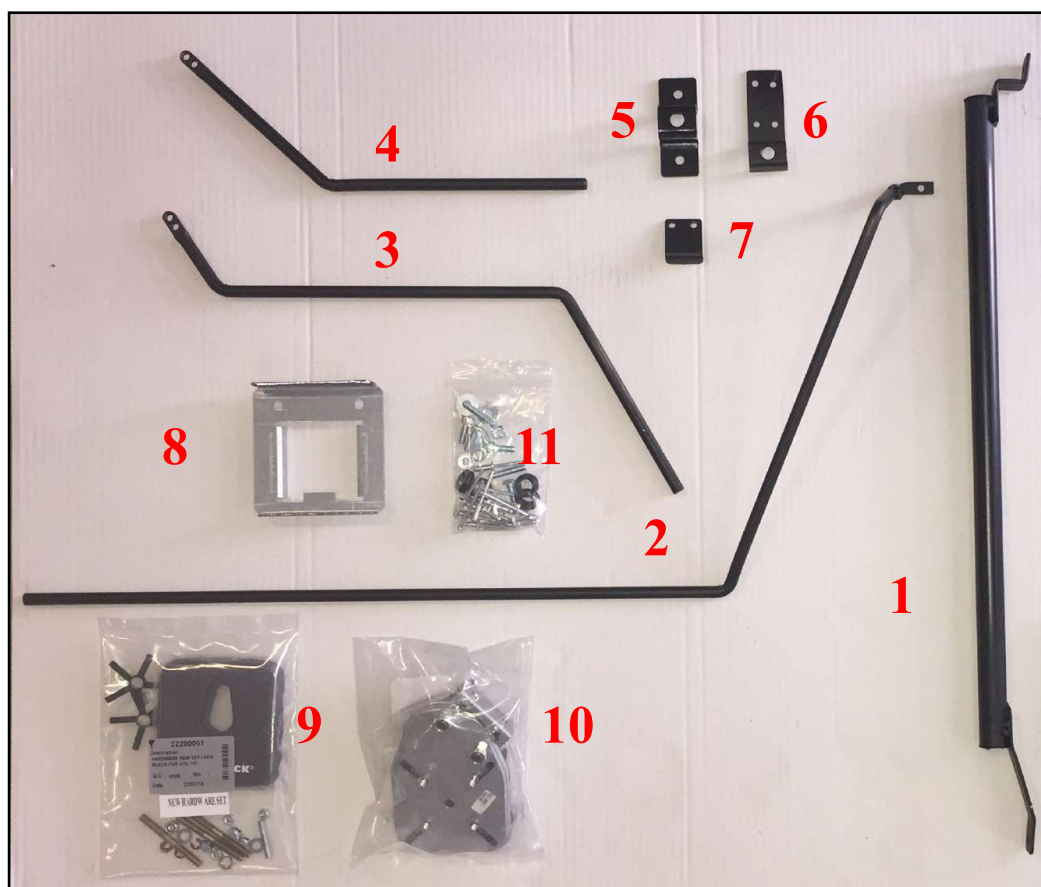

1. Guide tringle haute
2. Tringle haute
3. Tringle basse
4. Tringle latérale
5. Gâche latérale
6. Gâche basse
7. gâche haute
8. Support serrure

9. Cache serrure
10. Serrure 231
11. Visseries

# Matériel Utilisé Pour La Pose De Serrures



1. Lime plate
2. Pince multiprise
3. Mètre ruban
4. Cutter
5. Stylo feutre
6. Pince pour agrafe
7. Foret scie cloche Ø24
8. Foret Ø13
9. Foret Ø11
10. Foret Ø9
11. Foret Ø7
12. Foret Ø5
13. Foret étagé
14. Embout cruciforme pour visseuse
15. Clé à tube 10
16. Clé à tube 8
17. Clé plate 10
18. Marteau
19. Graisse
20. Tournevis cruciforme
21. Tournevis plat
22. Jeu de clé torx
23. Cisaille à main
24. Popeuse
25. Perceuse
26. Disqueuse
27. Antirouille (non fourni)

# Procédure : Etape 1

Retirer la garniture de la porte

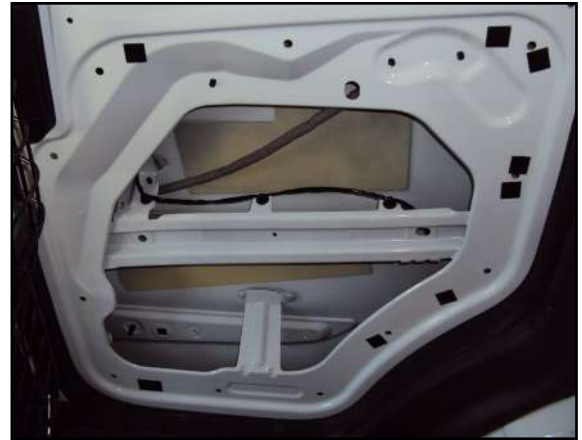
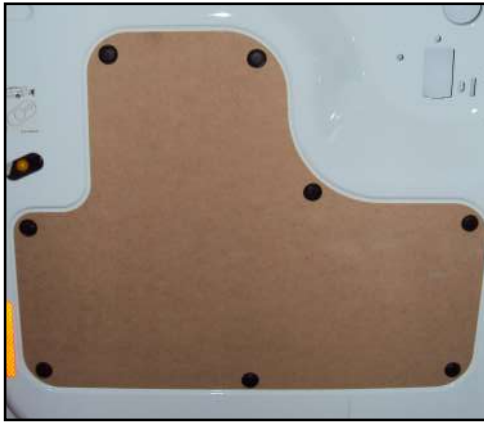

Positionner le gabarit de perçage



Tracer les différents trous

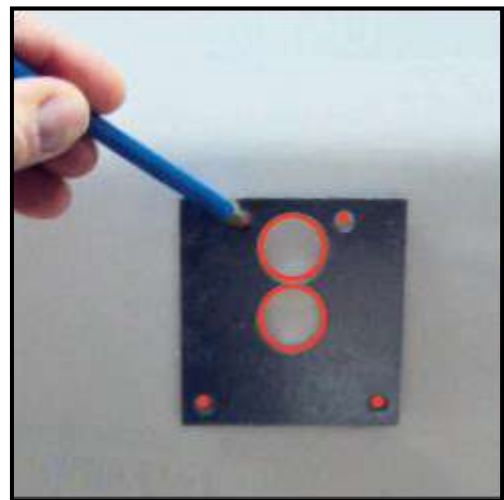

Percer les trous en fonction des diamètres indiqués sur l'image.

Limer l'excédent de matière afin d'obtenir un trou oblong.

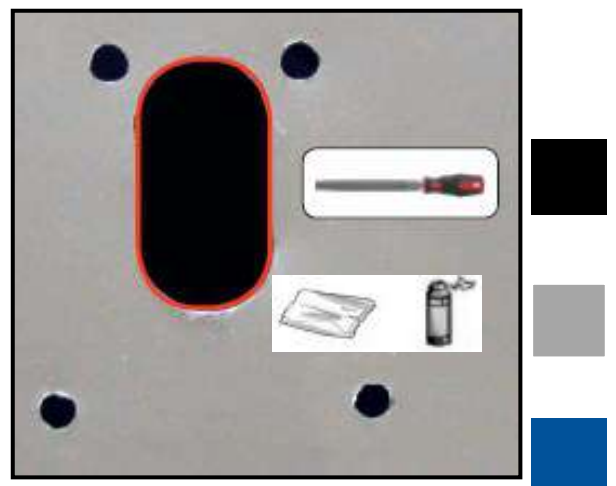
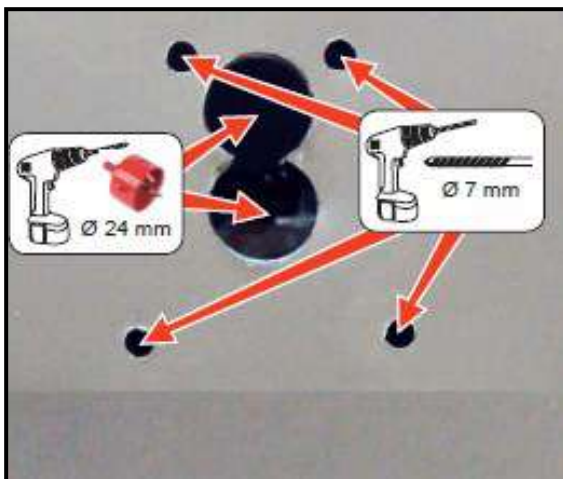

# Procédure : Etape 2

Après avoir serré les 4 tiges filetées sur le cache noir insérer son joint.

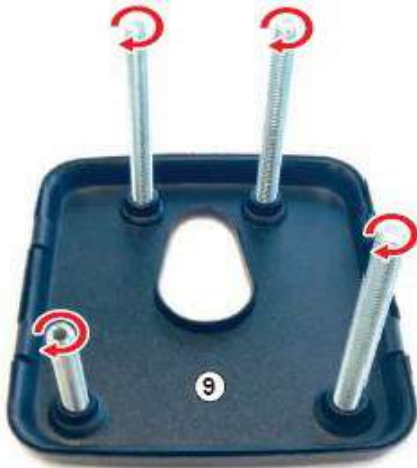

Insérer cette ensemble sur la portière.

Placer le support serrure



Fixer le support et la serrure à l'aide de 4 écrous M6.

Il ne faut pas trop serrer afin que **la plaque du support** et **la serrure** ne se touche pas.

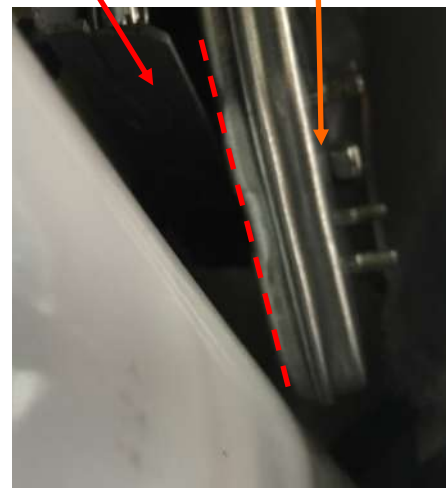
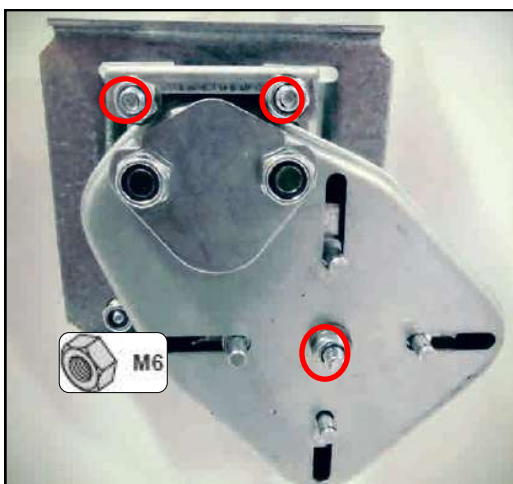

# Procédure : Etape 3

Mise en place de la tringle basse. Percer  $\varnothing 13$  suivant les cotes indiquées.

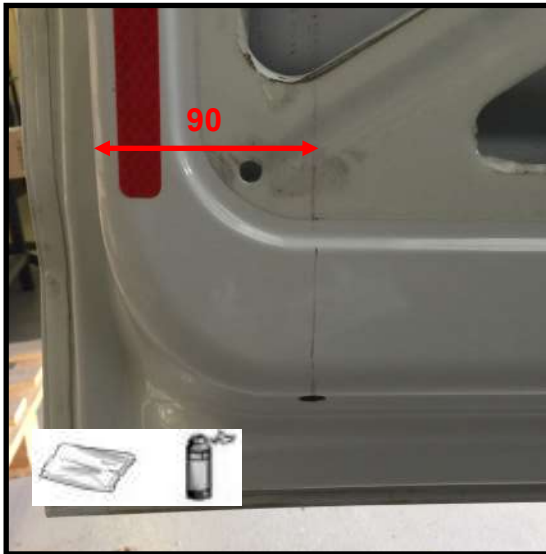

Placer la tringle latérale à l'aide de son écrous M5.



Retirer le plastique du marche pied, puis Fermer la porte et mettre la gâche sous la tringle. Trouver la position et percer  $\varnothing 5$

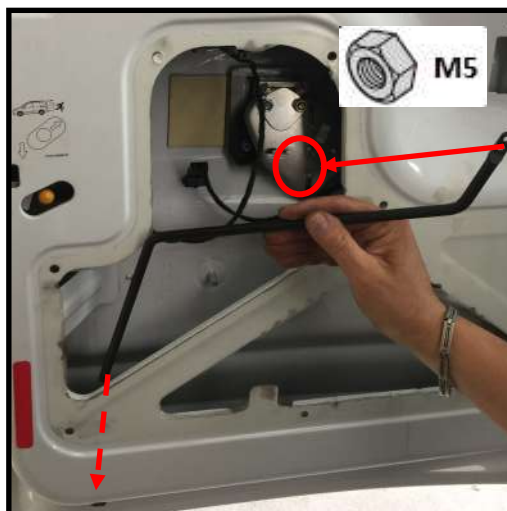

Fixer la gâche basse



Faire une découpe dans le marche pied.

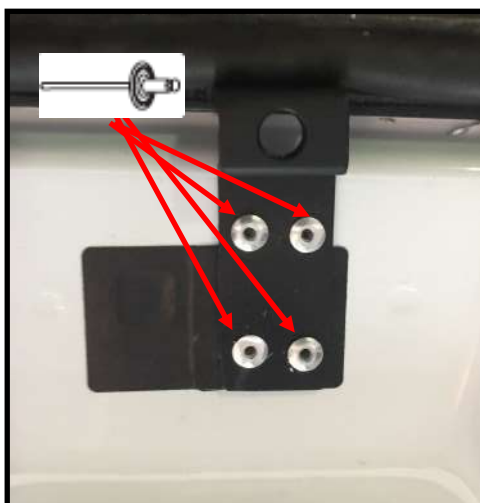

# Procédure : Etape 4

Fermer la porte et vérifier le bon fonctionnement de la serrure.



Mise en position de la tringle latérale.. Percer  $\varnothing 13$  un trou suivant les cotes indiquées,

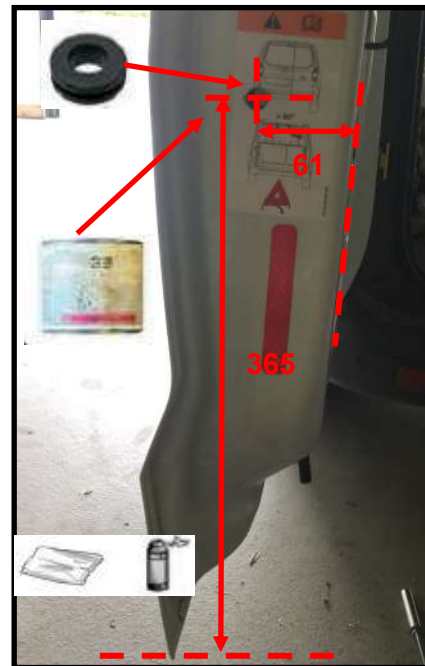

Fixer la tringle sur la serrure

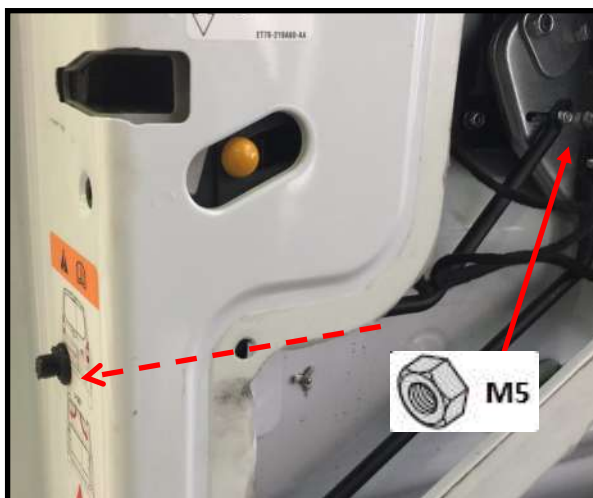

Enlever la garnitures sur la seconde porte



Fermer la porte, placer la **gâche latérale** centrée par rapport à la **tringle**.

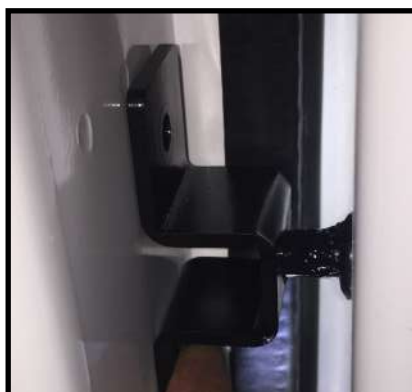

Repérer l'emplacement des trous de fixations, Percer  $\varnothing 7$ , fixer la gâche latérale par boulonnage, puis remettre la garniture.





# Procédure : Etape 5

**Fermer la porte et vérifier le bon fonctionnement de la serrure.**



Enlever la garniture du haut de la porte.



Enlever le guide tringle et positionner la tringle sur la serrure.

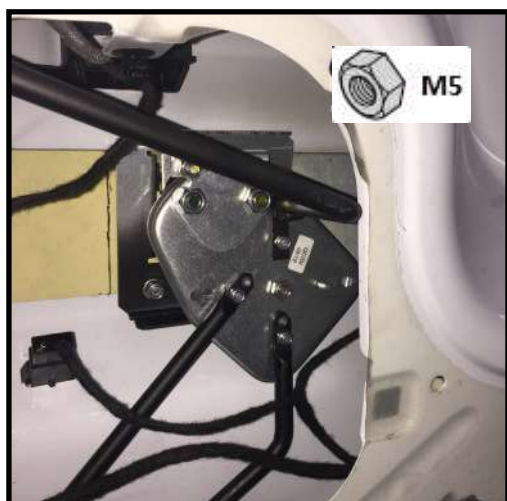

**Partie haute** : Placer le guide tringle en **buté** sur le **brossage** de la carrosserie.

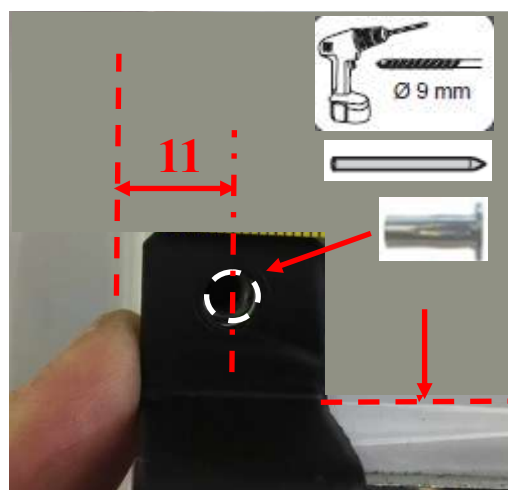

**Partie basse** : Se référer à la cote indiquée

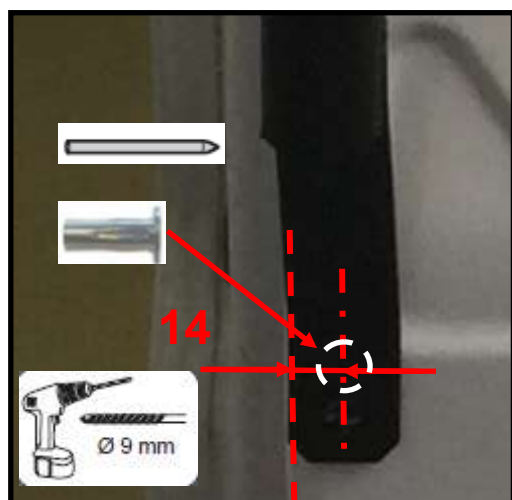

**Partie haute** : Fixer la partie haute

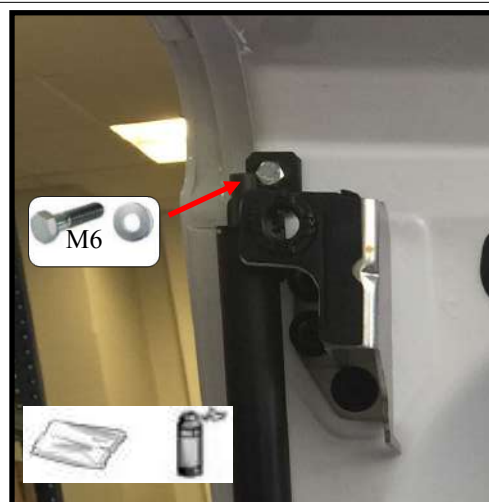

# Procédure : Etape 6

De même pour la partie basse.



Vérifier l'installation. Ensuite enlever le guide tringle.



Découpe de la garniture de la porte

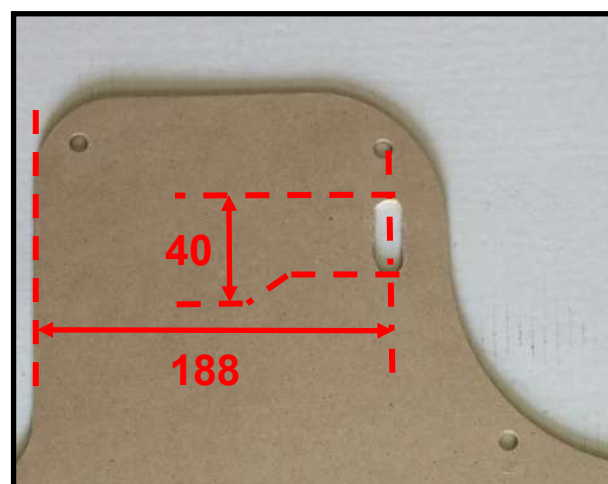
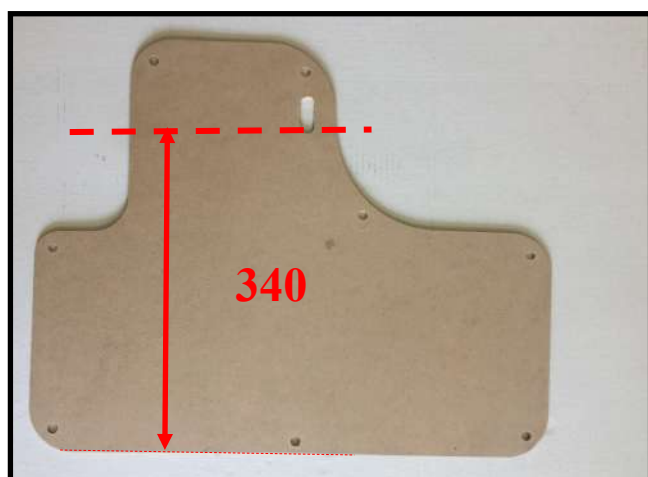

Replacer la garniture de la porte

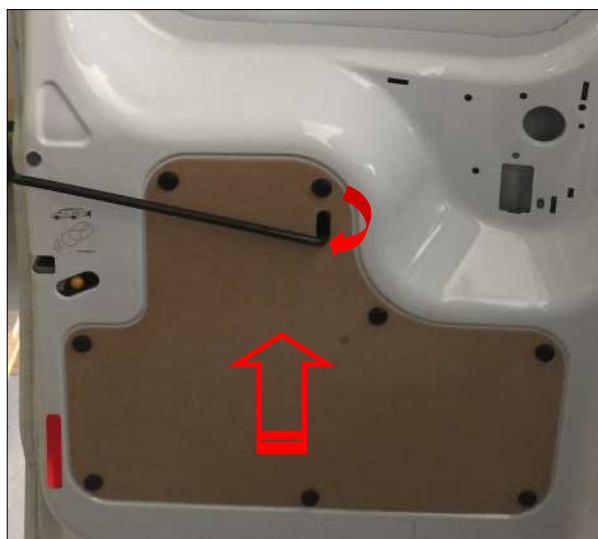

Refixer le guide tringle : partie haute et basse.

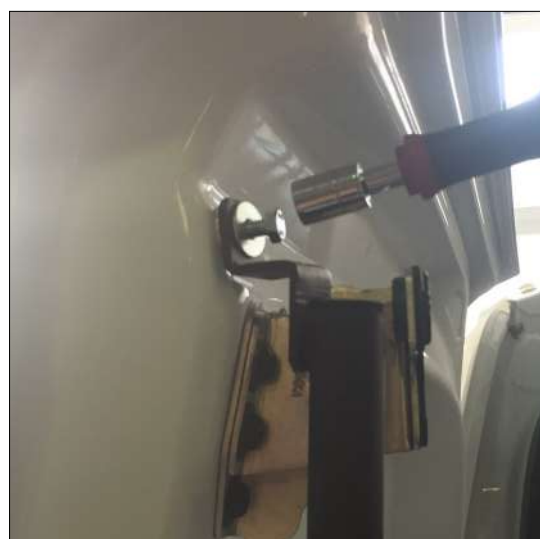

# Procédure : Etape 7

Enlever le plastique de la partie haute du véhicule.

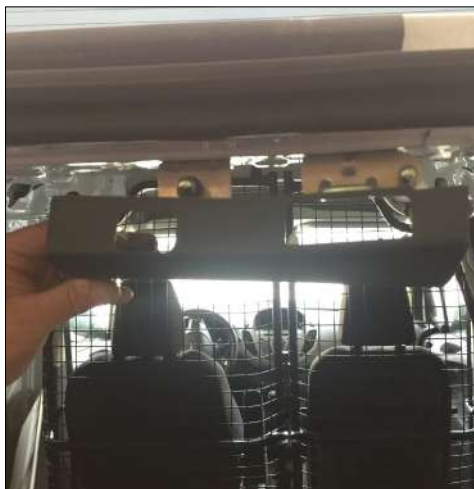

Fermer la porte, actionner la serrure et tracer l'emplacement des trous de fixations de la gâche, puis Percer Ø5.



Tracer l'emplacement de la gâche d'origine et dévisser le doigt de verrouillage d'origine pour pouvoir fixer la gâche comme sur la photo.

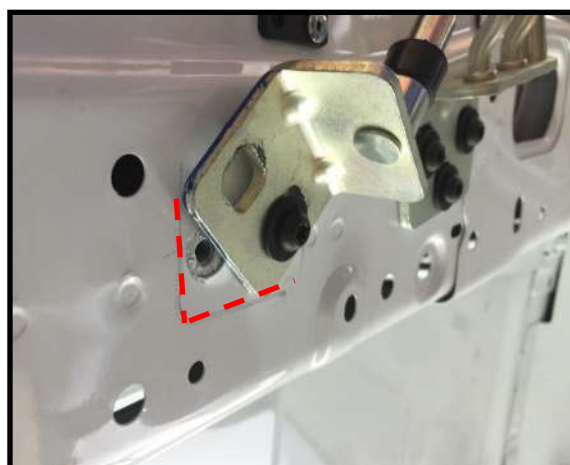
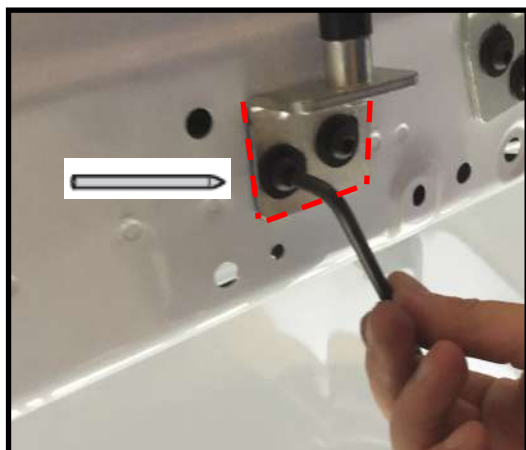

Fixer la gâche à l'aide de 2 rivets-pop et refixer le doigts de verrouillage dans sa position initial .

Repositionner le plastique

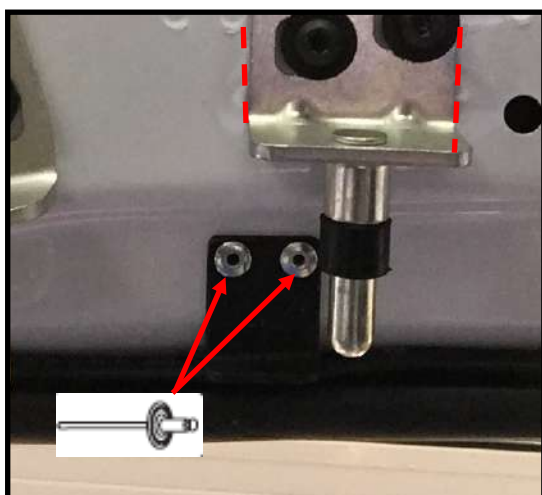

# Procédure : Etape 8



**Fermer la porte et vérifier le bon fonctionnement de la serrure.**



# Composition du Kit 1 point



1. Gâche latérale
2. Tringle latérale
3. Support serrure
4. Serrure 231
5. Cache serrure
6. Visseries

# Procédure : Etape 1

Retirer la garniture de la porte



Positionner le gabarit de perçage

Tracer les différents trous

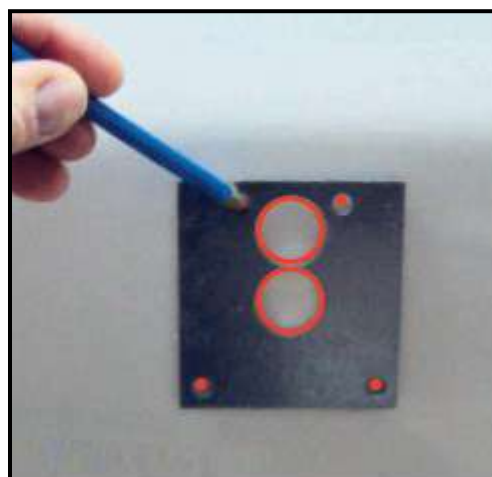
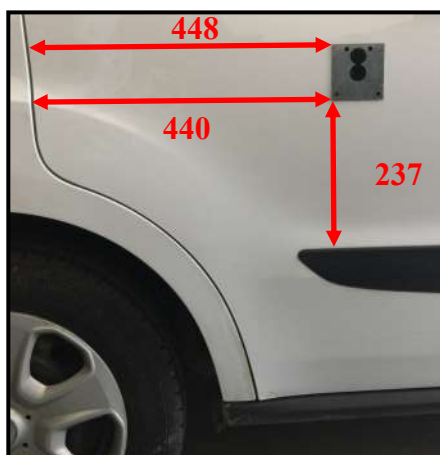

Percer les trous en fonction des diamètres indiqués sur l'image.

Limer l'excédent de matière afin d'obtenir un trou oblong.

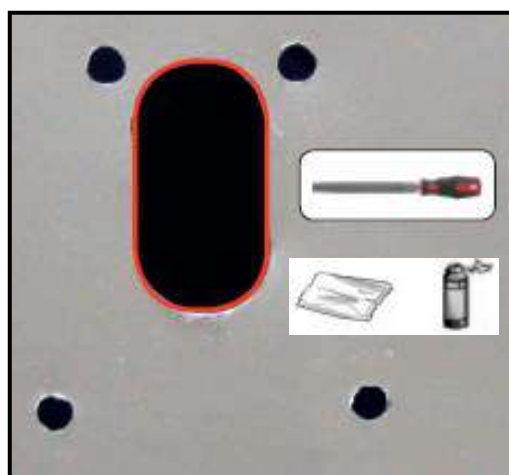
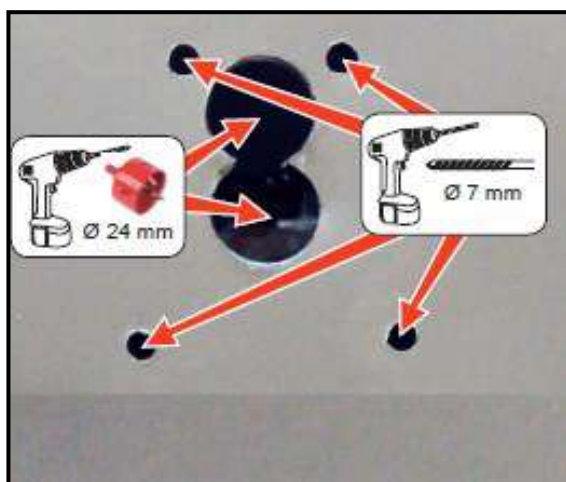

# Procédure : Etape 2

Après avoir serré les 4 tiges filetées sur le cache noir insérer son joint.

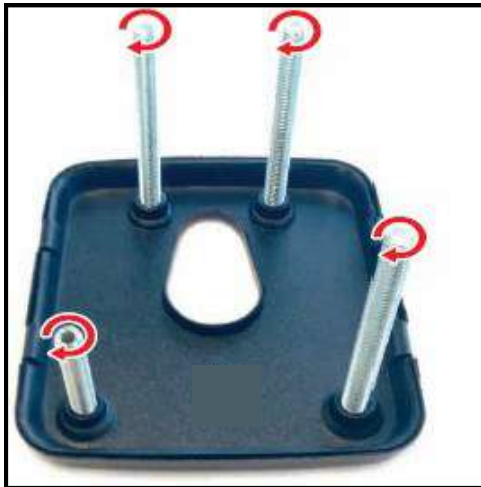

Insérer cette ensemble sur la portière.

Mettre en place le support serrure puis le fixer avec **1 écrou M6**



Fixer la serrure à l'aide de **3 écrous M6**



# Procédure : Etape 3

Mise en place de la tringle latérale **Percer Ø13** en positionnant le gabarit de perçage fournit sur votre notice.

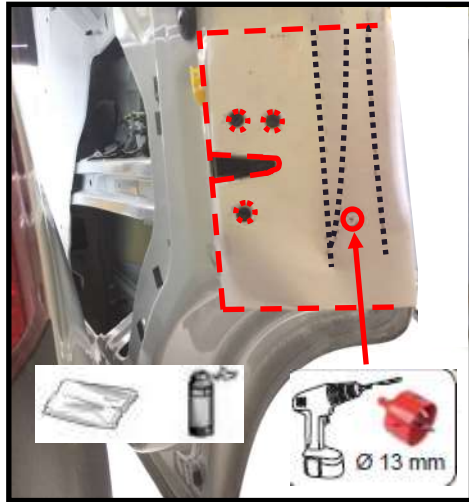

Insérer la tringle dans le trou percée plus tôt.



Fixer la tringle latérale



Placer de la graisse à son extrémité, elle servira à laisser **une empreinte** sur le montant du véhicule.



Puis fermer la porte, actionner la serrure : l'empreinte est réalisée. Percer Ø11 au centre de l'empreinte.

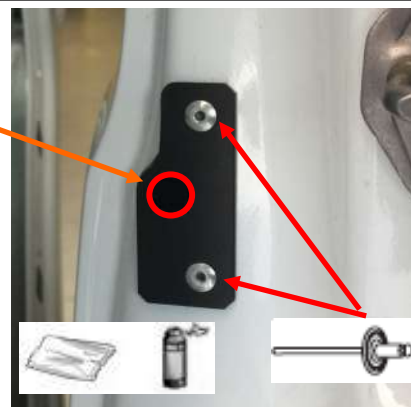



# Procédure : Etape 4



**Fermer la porte et vérifier le bon fonctionnement de la serrure.**





## GABARIT DE PERCAGE—SERRURE MUL-T-LOCK

- 1- Imprimer le Gabarit et vérifier l'échelle avant de l'utiliser
- 2- Découper le contour de la zone grise comme indiqué
- 3- Positionner le gabarit selon les indications de la notice
- 4- Repérer les points de perçage
- 5- Effectuer le perçage

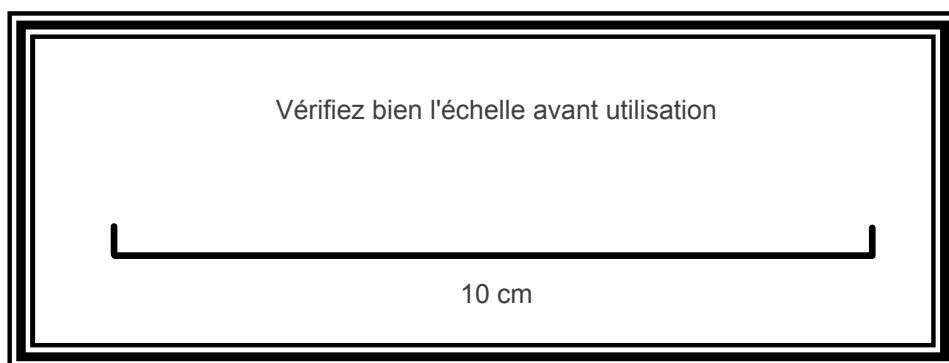
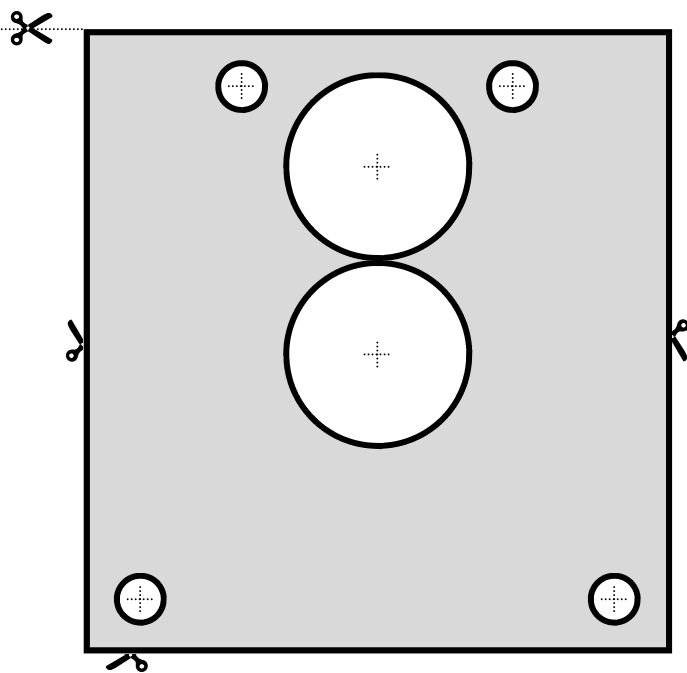







**MUL-T-LOCK®**



**DIVISION AUTOMOBILE MUL-T-LOCK**  
**533 AVENUE DU GENERAL DE GAULLE**  
**92140 CLAMART**  
**Tél : 01 41 28 39 70**  
**Fax : 01 69 53 01 85**  
**www.mul-t-lock.com**

**Support commercial**

**01.41.28.39.70**  
**adv@mul-t-lock.fr**



**Support technique**

**06.62.91.58.58**  
**automobile@mul-t-lock.fr**